

INTEX[®]

MILLWORK SOLUTIONS

Part# GCORNER

Intex Gutter System

Assembly Instructions and Parts List for Corner Splice Kit (Inside or Outside)

Corner Mount/Splice Kit Includes:

- (1) 3M VHB Die Cut Gasket (Item A)
- (1) 3M 94 Primer Ampule (Item B)
- (2) Wall Mounting Brackets (Item C)
- (2) Gutter Support Brackets (Item D)
- (2) #8 X 2-1/2" Flat Head Square Drive Screws (Item E)
- (2) #8 X 2-1/2" Flat Head Square Drive Screws (Item E)
- (3) Cortex Screws and Plugs (Item F)
- (4) #10 x 1" Pan Head Square Drive Screws (Item G)
- (4) #10 X 3" Flat Head Stainless Steel Screws (Item H)

Please note;

When installing gutter in temperatures below 50°F gutter surfaces that are to be joined must be heated with a heat gun prior to applying 3M gaskets and seals to ensure proper adhesion.

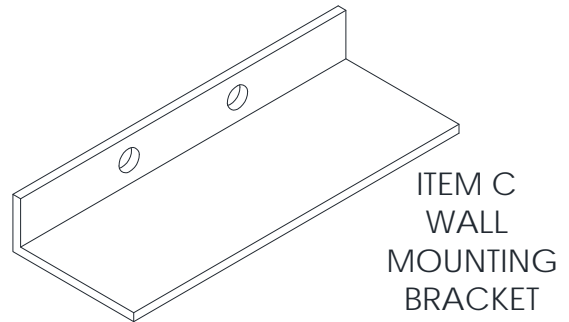
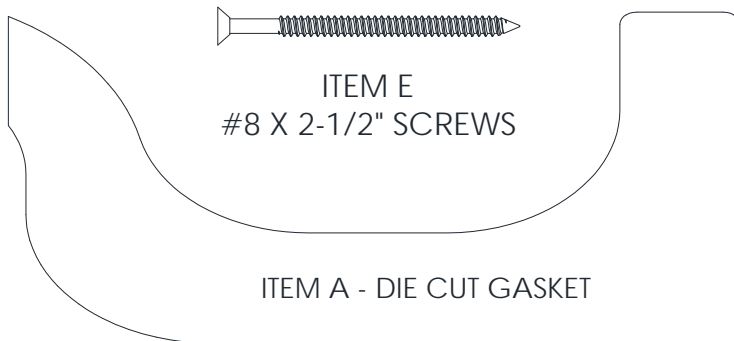

ITEM H
#10 X 3"
SCREWS



ITEM G
#10 X 1"
SCREWS



ITEM F

Cortex Screws with Plugs

ITEM B
PRIMER AMPULE

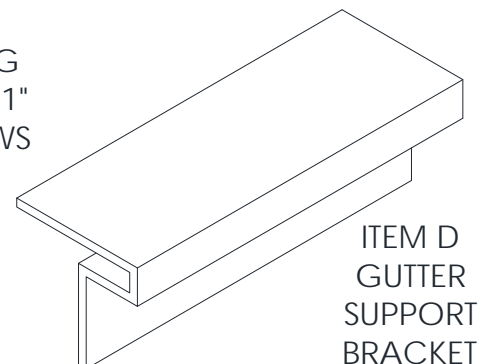

Preparation for use as Outside Corner

1. Cut both sections of gutter to be joined to the appropriate length and angle.
2. **Pocket Bore Joint** – Drill (3) 1/8 diameter pilot holes and, using a pocket bore jig, or use the **Intex Gutter Pocket Bore Fixture** (sold separately) drill (2) pocket bored holes as shown in **Figure C**.
3. **Prime Surfaces** – Prime Gutter surfaces to be joined using Primer Ampule **Item B**. Area must be clean of debris and dry. Squeeze black dot on side of Ampule. Using soft tip of applicator apply product to surfaces to be joined and allow to dry for 5 minutes.
4. **Apply Gasket** – Apply Die Cut Gasket **Item A**, to end of the Gutter by removing backer from Gasket and applying as shown in **Figure A**. Profile of Gasket should line up with **inside** edge of Gutter leaving a 1/8" reveal along outside edge of Gutter as shown in **Figure B**. Proper alignment is a critical step due to strength of the adhesive. Once in place rub your thumb over entire Gasket to insure a tight seal.
5. **Hang Wall Portion of Brackets** – Hang the two Wall Mounting Brackets **Item C**, approximately 4" - 6" from the corner, using four #10 X 3" flat head screws, **Item H**, as shown in **Figure D**. Vertical position of the Bracket is determined by Gutter's pitch established when installing the **Hanger Brackets**.

Assembly

1. Install **Gutter Hanger Bracket** (supplied separately) and hang two Gutter sections as described in the Hanger Bracket Installation Instructions leaving space between two sections being joined.
2. **Connect Gutter Sections** – Remove second backer from the Die Cut Gasket **Item A**. Align sections of gutter very carefully to ensure proper alignment. Slide sections of Gutter together and press firmly to join. Please note that once gasket surface touches gutter surface it will adhere immediately and readjustment will be difficult.
3. **Install Screws** - Install (1) #8 X 2-1/2" flat head square drive screw, **Item E**, into each pocket bore hole. Using the Cortex Driver Bit, install (1) Cortex Screw, **Item F**, into (3) 1/8" diameter pilot holes. Once all of the Cortex Screws are installed, plug each hole with (1) white plug. See **Figure C**.
4. **Fill Openings** – Once both pocket screws are installed, fill each pocket with acrylic latex caulk, Extreme PVC Trimwelder Fast Cure or equivalent product. Next fill the 1/16" seam along the front face and bottom of gutter (see **Figure F**), be sure to wipe away excess material from the surfaces before it fully cures.
6. **Install Gutter Support Brackets** – Place the two Gutter Support Brackets **Item D** over the 'shelf' portion of the Wall Mount Brackets, and secure to the back-inside surface of the gutter using 4 #10 x 1" screws Item. See **Figure E**

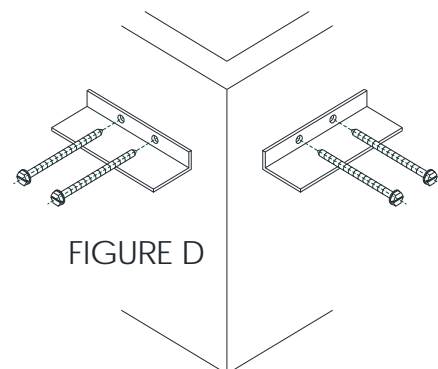
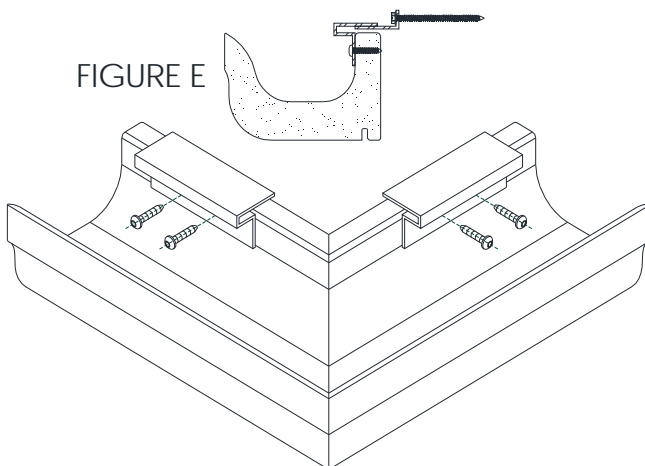
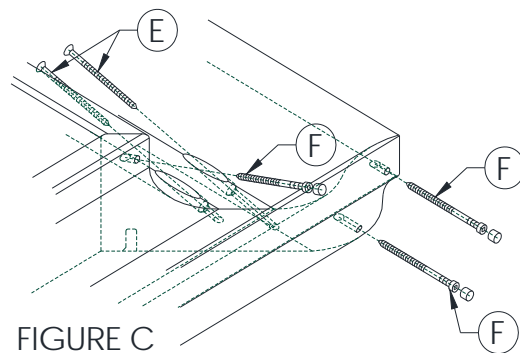
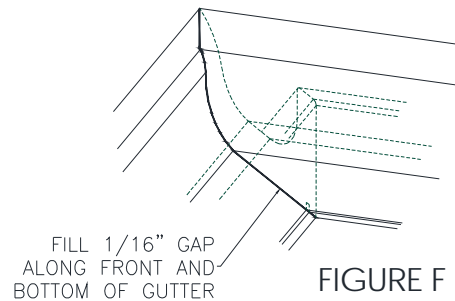
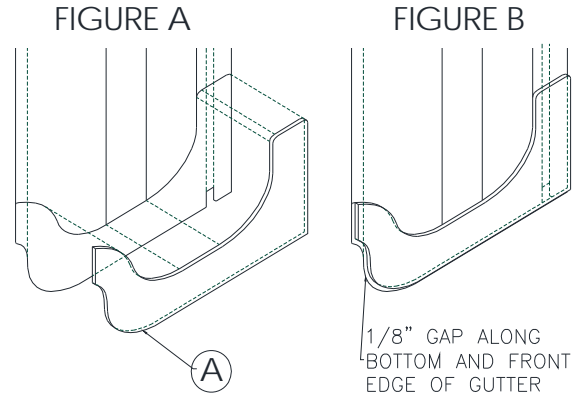

Preparation for use as Inside Corner

1. Cut both sections of gutter to be joined to the appropriate length and angle.
2. Pocket Bore Joint – Drill (3) 1/8 diameter pilot holes and, using a pocket bore jig, or use the Intex Gutter Pocket Bore Fixture (sold separately) drill (2) pocket bored holes as shown in Figure C.
3. Prime Surfaces – Prime Gutter surfaces to be joined using Primer Ampule Item B. Area must be clean of debris and dry. Squeeze black dot on side of Ampule. Using soft tip of applicator apply product to surfaces to be joined and allow to dry for 5 minutes.
4. Apply Gasket – Apply Die Cut Gasket Item A, to end of the Gutter by removing backer from Gasket and applying as shown in Figure A. Profile of Gasket should line up with inside edge of Gutter leaving a 1/8" reveal along outside edge of Gutter as shown in Figure B. Proper alignment is a critical step due to strength of the adhesive. Once in place rub your thumb over entire Gasket to insure a tight seal.
5. Hang Wall Portion of Brackets – Hang the two Wall Mounting Brackets Item C, approximately 4" - 6" from the corner, using four #10 X 3" flat head screws, Item H, as shown in Figure D. Vertical position of the Bracket is determined by Gutter's pitch established when installing the Hanger Brackets.

Assembly

1. Install Gutter Hanger Bracket (supplied separately) and hang two Gutter sections as described in the Hanger Bracket Installation Instructions leaving space between two sections being joined.
2. Connect Gutter Sections – Remove second backer from the Die Cut Gasket Item A. Align sections of gutter very carefully to ensure proper alignment. Slide sections of Gutter together and press firmly to join. Please note that once gasket surface touches gutter surface it will adhere immediately and readjustment will be difficult.
3. Install Screws - Install (1) #8 X 2-1/2" flat head square drive screw, Item E, into each pocket bore hole. Using the Cortex Driver Bit, install (1) Cortex Screw, Item F, into (3) 1/8" diameter pilot holes. Once all of the Cortex Screws are installed, plug each hole with (1) white plug. See Figure C.
4. Fill Openings – Once both pocket screws are installed, fill each pocket with acrylic latex caulk, Extreme PVC Trimwelder Fast Cure or equivalent product. Next fill the 1/16" seam along the front face and bottom of gutter (see Figure F), be sure to wipe away excess material from the surfaces before it fully cures.
5. Install Gutter Support Brackets – Place the two Gutter Support Brackets Item D over the 'shelf' portion of the Wall Mount Brackets, and secure to the back-inside surface of the gutter using 4 #10 x 1" screws Item. See Figure E

